

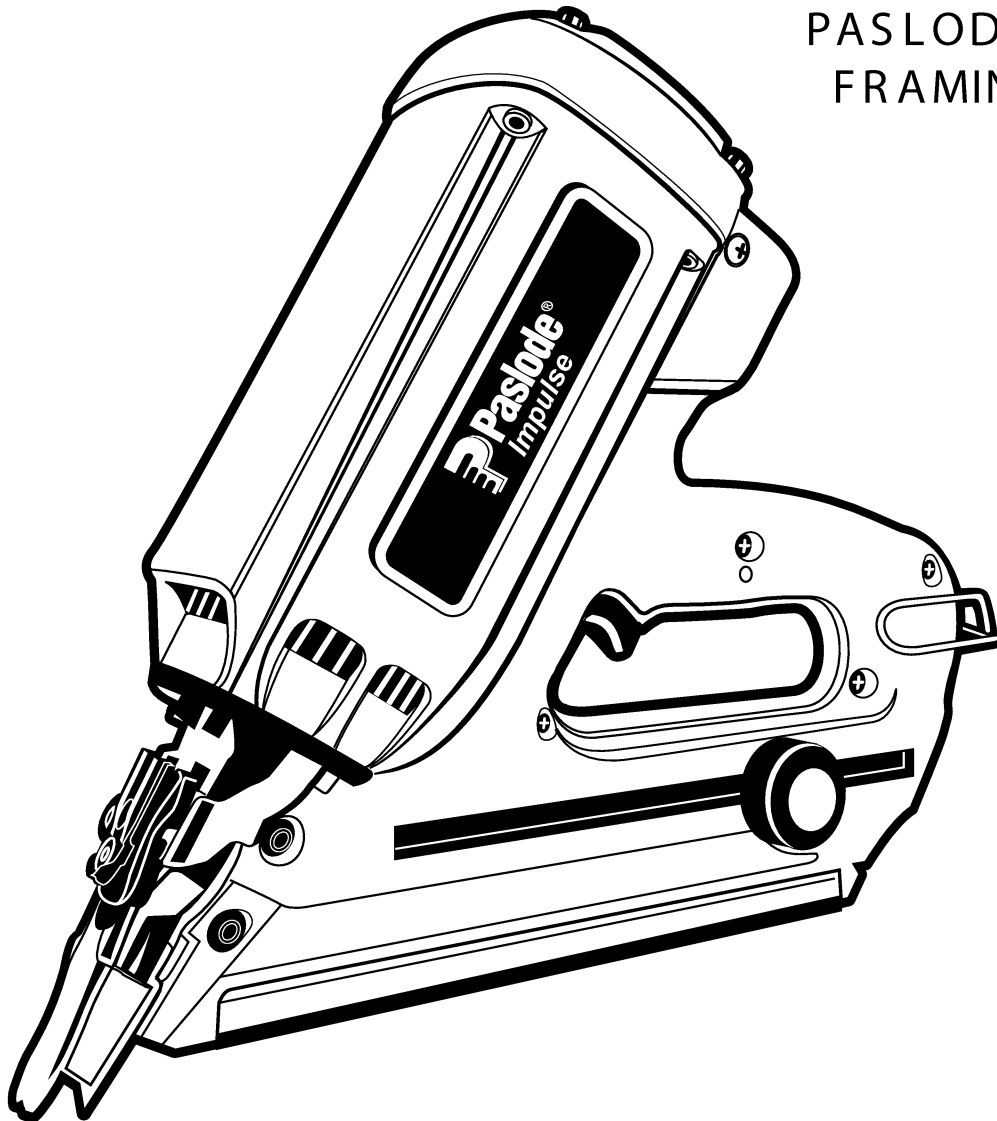

Part. No. 085000 (E.U.)
Part. No. 085010 (U.K.)



PASLODE IMPULSE FRAMING NAILER

TOOL SCHEMATIC AND PARTS

IMPORTANT! DO NOT DESTROY

Always refer to operating manual for detailed information on this tool. It is the customer's responsibility to have all operators and service personnel read and understand this information.

PARTS LEGEND Paslode Impulse FRAMING NAILER, 085000 085010

1	900320	1	Grill	51	404827	2	Pin
*2	900315	1	Filter	*52	404419	1	Bumper
3	013674	1	Fan Motor Assembly (Includes PC board, washer and flat retaining ring)	53	404411	3	Spring
4	900300	1	Retaining Ring (flat)	54	900934	2	Steel Ring, Sleeve
6	900470	1	Motor Mount	55	901204	1	Sleeve Assembly
7	401355	1	Retaining Ring (curved)	56	404464	2	Rubber Stop
8	901063	4	Shoulder Screw 10-24 x 1-1/2	57	404424	1	Reed Valve
*10	401356	1	Motor Sleeve	58	404422	1	Muffler
11	900286	1	Spark Plug Assembly, includes O-Ring	59	404423	1	Muffler Cover
12	404428	2	Push Rod	■ 61	900596	6	Screw Thread Forming Sems 8-32 x 7/16
13	404453	1	Bracket, Cylinder Head	▲ 62	013681	2	Socket Head Capscrew 10-24 x 1-1/8
14	404432	1	Bushing, Actuator	63	013682	2	Bushing, Shear Block
15	404444	1	Actuator	64	900975	1	Wear Plate, Nose
16	404433	1	Actuator Pin	65	901249	1	Upper Probe
17	401340	1	Stem Adapter	66	901239	1	Lower Probe
18	900471	1	Cylinder Head Machined	67	900592	2	S.H.C.S. Sems 10-32 x 1/2
*19	403992	1	O-Ring	68	401380	1	Tie Bar
20	403167	1	Fan Blade Assembly	70	404704	1	Housing Assembly
21	013677	1	Spark Unit Assembly	71	901251	1	Utility Hook Assembly
22	013676	1	Molded Circuit Assembly	72	013670	2	Label
23	900478	1	Spark Plug Contact Assembly	73	900980	1	Retainer Ring, Sleeve
24	900231	1	Clip, ESU Wire	→ 74	900593	3	S.H.C.S. Sems 10-24 x 5/8
25	403987	2	Screw Thread Forming 6-32 x 1/4	75	403985	1	Follower
26	013675	1	Handle Assembly Kit - Right & Left	76	900520	1	Follower Bushing Spring Assembly
27	013680	1	Roller Lever Assembly	77	901202	1	Retaining Ring
29	404702	2	Screw Thread Forming 6 x 3/8	78	403986	1	Spring Pin
30	404436	1	Nail Channel	79	403984	1	Follower Guide
31	404441	1	Cover Plate Magazine	80	900297	1	Follower Button
32	901222	2	Shoulder Screw 10-32 x 1/2	81	404457	1	Spring
33	900465	1	Cap	82	404922	2	Pad, Battery Contact
34	404412	1	Wear Plate, Chamber Lock	83	401450	5	Fuel Cell Pad
35	900453	4	Screw Plastite 8-16 x 7/8	85	901240	1	Probe Stop
** 36	013671	1	Warning Label	86	404426	1	Exhaust Baffle
37	404442	1	Channel Magazine	87	404425	1	Reed Plate
▲ 38	900594	4	S.H.C.S. Sems 8 - 32 x 1/2	88	900969	4	Torx Screw 8-32 x 5/8
39	901241	1	Spacer	89	900481	1	O-Ring
40	404451	1	Lockout Bar, Follower	**90	013672	1	Warning Label
41	901203	1	Shear Block	91	900372	1	Combustion Chamber Ring
42	901238	1	Spring, Flat	92	404407	1	Combustion Chamber
44	404435	1	Trigger	■ 93	900595	2	Torx Screw Sems 8-32 x 3/8
45	900269	1	Chamber Lock Bar	95	013673	1	Nameplate
46	404927	1	Spring, Trigger	96	900427	1	Light Pipe
47	401328	1	Retainer ring	97	900468	1	Washer, Motor Shaft
48	401461	2	Piston Ring	99	900546	1	Brass Insert
49	404485	1	Piston Assembly	100	900597	4	Screw Thread Forming Sems 6-19 x 3/8
50	900521	1	Combustion Chamber Assembly				

- * Denotes normal wear items
- ** Make sure Warning Labels (013671, 013672) are properly affixed. Replace if necessary. Label is available at no charge through the Service Department.
- ▲ Apply Loctite 242 (Blue) Part No. 093500.
- Apply Loctite RC-620 (Green) Part No. 401491
- Denotes new change.

SAFETY INSTRUCTIONS

WEAR EYE AND HEARING PROTECTION

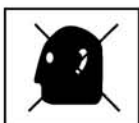

Always wear hearing protection and eye protection devices, including side shields when operating or working in the vicinity of a tool.

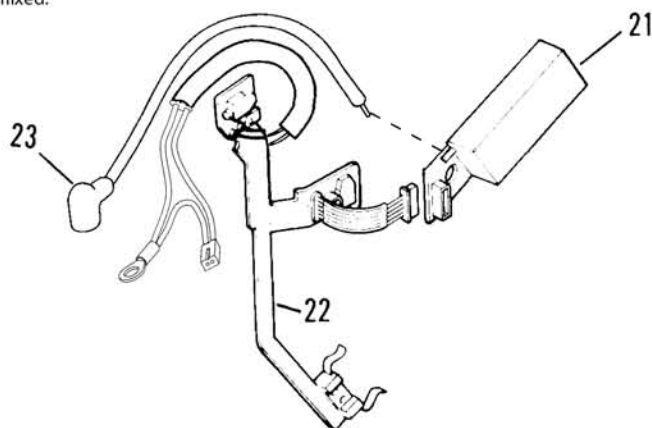

⚠ WARNING

All parts must be periodically inspected and replaced if worn or broken. Failure to do this can affect the tool's operation and present a safety hazard.

IMPULSE FRAMING NAILER

085000

085010

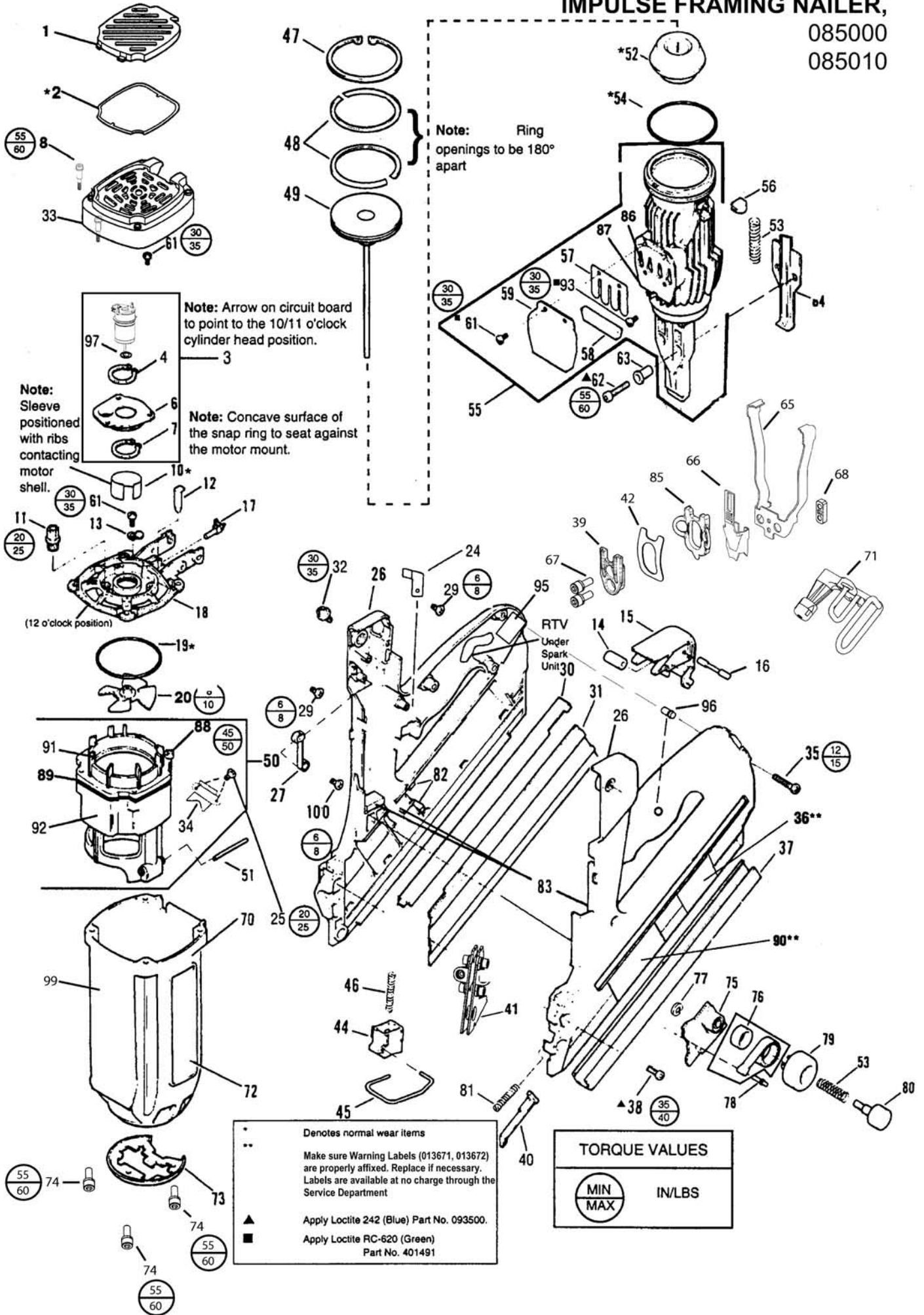

Note: Arrow on circuit board to point to the 10/11 o'clock cylinder head position.

Note: Sleeve positioned with ribs contacting motor shell.

Note: Concave surface of the snap ring to seat against the motor mount.

Note: Ring openings to be 180° apart

RTV Under Spark Unit

* Denotes normal wear items
 ** Make sure Warning Labels (013671, 013672) are properly affixed. Replace if necessary. Labels are available at no charge through the Service Department
 ▲ Apply Loctite 242 (Blue) Part No. 093500.
 ■ Apply Loctite RC-620 (Green) Part No. 401491

TORQUE VALUES	
MIN	IN/LBS
MAX	

ACCESSORIES

Car Adapter

Enables you to re-charge your battery with your vehicle's electrical system.



Part No. 900507

Battery Cell



Part No. 404717

Paslode Cordless Oil



Part No. 401482

5/32" Hex Key

For adjusting work contacting element.



Part No. 401331

No-Mar Work Contacting Element

Rubber tipped WCE to eliminate marring work surface.
(Replacement rubber tip, Part No. 403369)



Part No. 012082

Paslode Cordless Nailer Case

Part No. 404710

Clear Safety Glasses



Part No. 402510

Orange Safety Glasses



Part No. 011117

Tinted Safety Glasses

Part No. 402512

Degreaser Cleaner

Ideal cleaner for all Paslode™ tools.

Part No. 115251

Battery Charger Kit

(Replacement Charger Base Only Part No. 035460)

(Replacement Transformer Only Part No. 900477- US/CANADA)

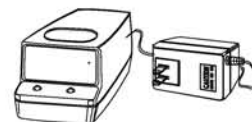

Part No. 900200

(Replacement Transformer Only Part No. 900505 Continental Europe)

(Replacement Transformer Only Part No. 900506 U.K.)

(Replacement Transformer Only Part No. 900504 Australia)



Route de Lyon
B.P. 104
F-26501 Bourg-lès-Valence

013683
05/06