

**Centre Scientifique et
Technique du Bâtiment**

84 avenue Jean Jaurès
CHAMPS-SUR-MARNE
F-77447 Marne-la-Vallée Cedex 2

Tél. : (33) 01 64 68 82 82

Fax : (33) 01 60 05 70 37

**European Technical
Assessment**

**ETA-13/0005
of 15/12/2014**

English translation prepared by CSTB - Original version in French language

General Part

Nom commercial
Trade name

SPIT FIX3

Famille de produit
Product family

Cheville métallique à expansion par vissage à couple contrôlé, de fixation dans le béton non fissuré: diamètres M8, M10, M12 M16 et M20.

Torque-controlled expansion anchor for use in non cracked concrete: sizes M8, M10, M12 M16 et M20

Titulaire
Manufacturer

Société Spit
Route de Lyon
F-26501 BOURG-LES-VALENCE
France

Usine de fabrication
Manufacturing plants

Société Spit
Route de Lyon
F-26501 BOURG-LES-VALENCE
France

Cette évaluation contient:
This Assessment contains

12 pages incluant 9 annexes qui font partie intégrante de cette évaluation
12 pages including 9 annexes which form an integral part of this assessment

Base de l'ETE
Basis of ETA

ETAG 001, Version April 2013, utilisée en tant que EAD
ETAG 001, Edition April 2013 used as EAD

Cette évaluation remplace:
This Assessment replaces

ATE-13/0005 valide du 01/05/2013 au 30/04/2018
ETA-13/0005 with validity from 01/05/2013 to 30/04/2018

Translations of this European Technical Assessment in other languages shall fully correspond to the original issued document and should be identified as such. Communication of this European Technical Assessment, including transmission by electronic means, shall be in full. However, partial reproduction may be made, with the written consent of the issuing Technical Assessment Body. Any partial reproduction has to be identified as such.

Specific Part

1 Technical description of the product

The SPIT FIX3 anchor is an anchor made of zinc electroplated steel which is placed into a drilled hole and anchored by torque-controlled expansion.

The illustration and the description of the product are given in Annexes A.

2 Specification of the intended use

The performances given in Section 3 are only valid if the anchor is used in compliance with the specifications and conditions given in Annexes B.

The provisions made in this European technical assessment are based on an assumed working life of the anchor of 50 years. The indications given on the working life cannot be interpreted as a guarantee given by the producer, but are to be regarded only as a means for choosing the right products in relation to the expected economically reasonable working life of the works.

3 Performance of the product

3.1 Mechanical resistance and stability (BWR 1)

Essential characteristic	Performance
Characteristic tension resistance acc. ETAG001, Annex C	See Annex C 1
Characteristic shear resistance acc. ETAG001, Annex C	See Annex C 2
Characteristic tension resistance acc. CEN/TS 1992-4	See Annex C 3
Characteristic shear resistance acc. CEN/TS 1992-4	See Annex C 4
Displacements	See Annex C 5

3.2 Safety in case of fire (BWR 2)

Essential characteristic	Performance
Reaction to fire	Anchorage satisfy requirements for Class A1

3.3 Hygiene, health and the environment (BWR 3)

Regarding dangerous substances contained in this European technical approval, there may be requirements applicable to the products falling within its scope (e.g. transposed European legislation and national laws, regulations and administrative provisions). In order to meet the provisions of the Construction Products Directive, these requirements need also to be complied with, when and where they apply.

3.4 Safety in use (BWR 4)

For Basic requirement Safety in use the same criteria are valid as for Basic Requirement Mechanical resistance and stability.

3.5 Protection against noise (BWR 5)

Not relevant.

3.6 Energy economy and heat retention (BWR 6)

Not relevant.

3.7 Sustainable use of natural resources ((BWR 7)

For the sustainable use of natural resources no performance was determined for this product.

3.8 General aspects relating to fitness for use

Durability and Serviceability are only ensured if the specifications of intended use according to Annex B 1 are kept.

4 Assessment and verification of constancy of performance (AVCP)

According to the Decision 96/582/EC of the European Commission¹, as amended, the system of assessment and verification of constancy of performance (see Annex V to Regulation (EU) No 305/2011) given in the following table apply.

Product	Intended use	Level or Class	System
Metal anchors for use in concrete	For fixing and/or supporting to concrete, structural elements (which contributes to the stability of the works) or heavy units	—	1

5 Technical details necessary for the implementation of the AVCP system

Technical details necessary for the implementation of the Assessment and verification of constancy of performance (AVCP) system are laid down in the control plan deposited at Centre Scientifique et Technique du Bâtiment.

The manufacturer shall, on the basis of a contract, involve a notified body approved in the field of anchors for issuing the certificate of conformity CE based on the control plan.

Issued in Marne La Vallée on 15-12-2014 by
Charles Baloche
Directeur technique

The original French version is signed

¹ Official Journal of the European Communities L 254 of 08.10.1996

Assembled anchor and schema of the anchor in use

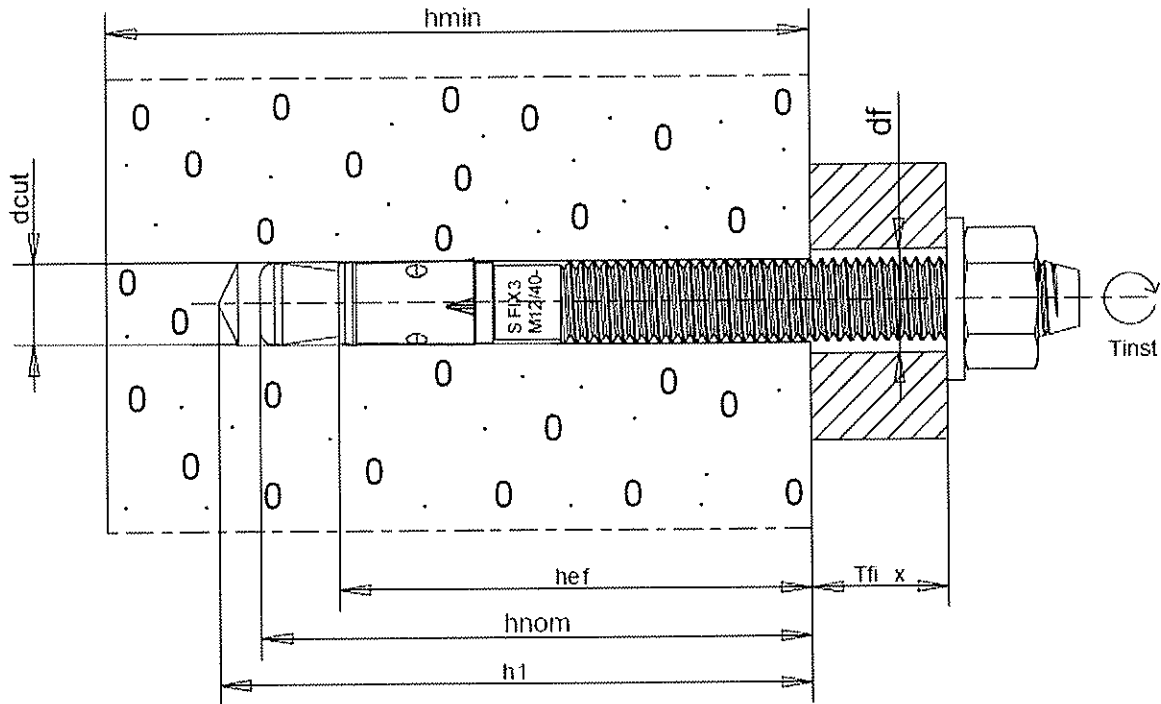

- hef : Effective anchorage depth
- h_{nom} : Installation depth
- h₁ : Depth of drilled hole to deepest point
- t_{fix} : Fixture thickness

<p>SPIT FIX3 torque-controlled expansion anchor</p>	<p>Annex A1</p>
<p>Product description Installation condition</p>	

Different parts of the anchor:

- Type with no slit clip (available for size M8, M10, M12, M16, M20)

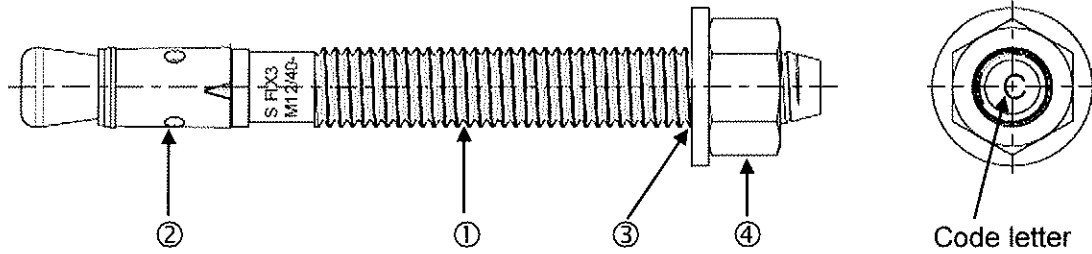

- Type with slit clip (available for size M12)

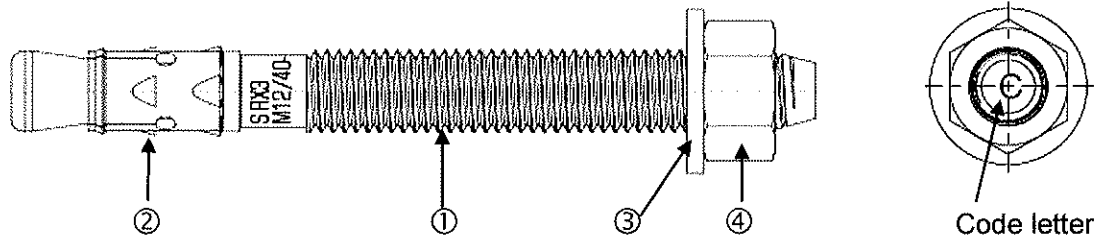

Marking : S FIX 3 M12/40-25

S : Producer SPIT
 FIX 3 : Commercial name
 M12 : Size of anchor
 40-25 : Maximum and minimum thickness of the fixture

Table 1: Materials

Part	Designation	Material	Protection
①	Bolt	M8, M10, M12, M16 and M20 : Cold formed NF A 35-053	NF EN 12 329 Galvanized $\geq 5 \mu\text{m}$
②	Clip	Cold formed: NF A 35-231	M8-M16 : NF EN 10152 M20 : NF EN 12329 Galvanized $\geq 5 \mu\text{m}$
③	Washer	NF E 25 513	NF EN ISO 4042 Galvanized $\geq 5 \mu\text{m}$
④	Nut	Steel grade 6 or 8 acc. ISO 898-2	

Table 2 : Washers dimensions

Anchor size		M8	M10	M12	M16	M20	
Washer sizes		d1 (mm) inner \varnothing	8,4	10,5	13	17	21
Washer type	Narrow (standard version)	d2 (mm) outer \varnothing	16	20	24	30	36
	Broad	d2 (mm) outer \varnothing	18	22	32	40	50
	X-broad	d2 (mm) outer \varnothing	22	27	40	50	60

SPIT FIX3 torque-controlled expansion anchor

Product description
 Materials

Annex A2

Specifications of intended use

Anchorage subject to:

- Static or quasi-static loads

Base materials:

- Reinforced or unreinforced normal weight concrete of strength classes C 20/25 at least to C50/60 at most according to EN 206: 2000-12.
- Non-cracked concrete

Use conditions (Environmental conditions):

- Structures subject to dry indoor conditions, indoor with temporary condensation.

Design:

- The anchorages are designed in accordance with the ETAG001 Annex C "Design Method for Anchorages" or CEN/TS 1992-4-4 "Design of fastenings for use in concrete" under the responsibility of an engineer experienced in anchorages and concrete work.
- Verifiable calculation notes and drawings are prepared taking account of the loads to be anchored. The position of the anchor is indicated on the design drawings.

Installation:

- Anchor installation carried out by appropriately qualified personnel and under the supervision of the person responsible for technical matters of the site.
- Use of the anchor only as supplied by the manufacturer without exchanging the components of an anchor.
- Anchor installation in accordance with the manufacturer's specifications and drawings and using the appropriate tools.
- Effective anchorage depth, edge distances and spacing not less than the specified values without minus tolerances.
- In case of aborted hole, drilling of new hole at a minimum distance of twice the depth of the aborted hole, or smaller distance provided the aborted drill hole is filled with high strength mortar and no shear or oblique tension loads in the direction of aborted hole.

SPIT FIX3 torque-controlled expansion anchor	Annex B1
Intended Use Specifications	

Table 3: Setting data

	L (mm)	Code letter	d ₀ (mm)	d _r (mm)	T _{inst} (Nm)	Minimal embedment depth h _{ef,min}					Maximal embedment depth h _{ef,max}				
						h _{min} (mm)	h ₁ (mm)	h _{nom} (mm)	h _{ef,min} (mm)	t _{fix,max} (mm)	h _{min} (mm)	h ₁ (mm)	h _{nom} (mm)	h _{ef,max} (mm)	t _{fix,max} (mm)
	0		(1)	(2)	(3)	(4)	(5)	(6)	(7)	(8)	(4)	(5)	(6)	(7)	(8)
M8x55/5	51,9	-	8	9	15	80	50	38	30	5	80	60	48	40	-
M8x70/20-10	66,9	C								20					10
M8x90/40-30	86,9	E								40					30
M8x100/50-40	96,9	F								50					40
M8x115/65-55	111,9	G								65					55
M8x130/80-70	126,9	H								80					70
M8x160/110-100	157,4	J								110					100
M10x65/5	65,9	-	10	12	30	100	60	50	40	5	100	70	60	50	-
M10x75/15-5	75,9	C								15					5
M10x85/25-15	85,9	D								25					15
M10x95/36-26	96,9	E								36					26
M10x110/50-40	110,9	F								50					40
M10x125/65-55	125,9	G								65					55
M10x140/80-70	140,9	I								80					70
M10x160/100-90	161,4	J	100	90											
M12x80/5	81,2	-	12	14	50	100	75	62	50	5	130	90	77	65	-
M12x100/25-10	101,2	F								25					10
M12x115/40-25	116,2	G								40					25
M12x125/50-35	126,2	H								50					35
M12x140/65-50	141,2	I								65					50
M12x160/85-70	161,2	J								85					70
M12x180/105-90	181,2	L								105					90
M12x220/145-130	221,7	O	145	130											
M16x100/5	103,9	-	16	18	100	130	95	80	65	5	160	110	95	80	-
M16x125/30-15	128,9	G								30					15
M16x150/55-40	153,9	I								55					40
M16x170/75-60	173,9	K								75					60
M16x185/90-75	189,4	L								90					75
M20x125/10	125,4	-	20	22	160	150	110	93	75	10	200	135	118	100	-
M20x165/50-25	165,4	J								50					25
M20x220/105-80	220,4	N								105					80

* use restricted to anchoring of structural components statically indetermined.

(0) Total length of the bolt (mm)

(1) Nominal diameter of drill bit, d_{cut} (mm)

(2) Diameter of clearance hole in the fixture, d_r (mm)

(3) Required torque moment, T_{inst} (Nm)

(4) Minimum thickness of concrete member, h_{min} (mm)

(5) Depth of drilled hole to deepest point, h₁ (mm)

(6) Minimum installation depth, h_{nom} (mm)

(7) Effective anchorage depth, h_{ef} (mm)

(8) Maximum thickness of the fixture, t_{fix,max} (mm)

Table 4 : Minimum spacing and edge distance

Non- cracked concrete only				M8	M10	M12	M16	M20
Effective anchorage depth h _{ef,min}	Slab thickness	h _{min}	[mm]	80	100	100	130	150
	Minimum spacing	S _{min}	[mm]	40	40	50	100	100
	Minimum edge distance	C _{min}	[mm]	50	45	65	100	115
Effective anchorage depth h _{ef,max}	Slab thickness	h _{min}	[mm]	80	100	130	160	200
	Minimum spacing	S _{min}	[mm]	45	60	70	90	100
	Minimum edge distance	C _{min}	[mm]	55	65	70	105	120

SPIT FIX3 torque-controlled expansion anchor

Intended Use
Installation data

Annex B2

Table 5 : Characteristic resistances in tension loads
Design method A acc. **ETAG001, Annex C**

Anchor size			M8		M10		M12		M16		M20	
Steel failure												
Characteristic resistance	$N_{Rk,s}$	[kN]	17,8		26,0		42,1		72,7		103,2	
Partial safety factor	$\gamma_{Ms}^{2)}$	-	1,50				1,47		1,40			
Pull-out failure												
Effective anchorage depth	h_{ef}	[mm]	30 ¹⁾	40	40	50	50	65	65	80	75	100
Characteristic resistance	$N_{Rk,p}$	[kN]	7,5	3)	3)	3)	3)	3)	3)	3)	3)	3)
Partial safety factor	$\gamma_{Mp}^{2)}$	-	1,5 ⁴⁾									
Increasing factor for $N_{Rk,p}$	$\psi_c^{5)}$	-	$\psi_c = \left(\frac{f_{ck,cube}}{25}\right)^{0,5}$									
Concrete cone failure and splitting failure⁶⁾												
Effective anchorage depth	h_{ef}	[mm]	30	40	40	50	50	65	65	80	75	100
Slab thickness	h_{min}	[mm]	80 100	80 100	100	100	100	130	130	160	150	200
Spacing	$s_{cr,N}$	[mm]	90	120	120	150	150	195	195	240	225	300
	$s_{cr,sp}$	[mm]	250 170	300 230	210	250	200	340	320	330	370	370
Edge distance	$c_{cr,N}$	[mm]	45	60	60	75	75	97,5	97,5	120	112,5	150
	$c_{cr,sp}$	[mm]	125 85	150 115	105	125	100	170	160	165	185	185
Partial safety factor	$\gamma_{Mc}^{2)}$ $\gamma_{Msp}^{2)}$	-	1,5 ⁴⁾									

- 1) Use restricted to anchoring of structural components statically indetermined.
- 2) In absence of other national regulation.
- 3) The pull-out failure mode is not decisive for design.
- 4) The installation safety factor $\gamma_2=1.0$ is included.
- 5) Use concrete strength class according to EN 206-1, the maximum concrete strength is limited to $f_{ck,cube}=60N/mm^2$.
- 6) To give proof of splitting failure due to loading use the smaller value of $N_{Rk,p}$ and $N_{Rk,c}^0$ in equation 5.3 according to ETAG001 Annex C

SPIT FIX3 torque-controlled expansion anchor

Design according to **ETAG001, Annex C**
Characteristic resistances under tension loads

Annex C1

Table 6: Characteristic resistances in shear loads
Design method A acc. **ETAG001, Annex C**

Anchor size			M8 ¹⁾		M10		M12		M16		M20	
Effective anchorage depth	h_{ef}	[mm]	30	40	40	50	50	65	65	80	75	100
Steel failure without lever arm												
Characteristic resistance	$V_{Rk,s}$	[kN]	10,0		13,7		27,4		36,5		71,1	
Partial safety factor	γ_{Ms} ²⁾	-	1,25		1,25		1,25		1,25		1,50	
Steel failure with lever arm												
Characteristic resistance	$M^0_{Rk,s}$	[N.m]	24,0		49,0		85,0		200,0		376,0	
Partial safety factor	γ_{Ms} ²⁾	-	1,25		1,25		1,25		1,25		1,50	

Concrete pry-out failure												
k factor	k	-	1,0		1,0		1,0		2,0		2,0	
Partial safety factor	γ_{Mc} ²⁾	-	1,50 ³⁾									

Concrete edge failure												
Effective length of anchor under shear loading	l_f	[mm]	30	40	40	50	50	65	65	80	75	100
Outside diameter of anchor	d_{nom}	[mm]	8		10		12		16		20	
Partial safety factor	γ_{Mc} ²⁾	-	1,50 ³⁾									

- 1) Use restricted to anchoring of structural components statically indetermined.
- 2) In absence of other national regulation.
- 3) The installation safety factor $\gamma_2=1.0$ is included.
- 4) k factor in equation (5.6) of ETAG001 Annex C, § 5.2.3.3.

SPIT FIX3 torque-controlled expansion anchor

Design according to **ETAG001, Annex C**
Characteristic resistances under shear loads

Annex C2

Table 7 : Characteristic resistances in tension loads
Design method A acc. **CEN/TS 1992-4**

Anchor size			M8		M10		M12		M16		M20		
Steel failure													
Characteristic resistance	$N_{RK,s}$	[kN]	17,8		26,0		42,1		72,7		103,2		
Partial safety factor	$\gamma_{Ms}^{2)}$	-	1,50						1,47		1,40		
Pull-out failure													
Effective anchorage depth	h_{ef}	[mm]	30 ¹⁾	40	40	50	50	65	65	80	75	100	
Characteristic resistance	$N_{RK,p}$	[kN]	7,5	3)	3)	3)	3)	3)	3)	3)	3)	3)	
Partial safety factor	$\gamma_{Mp}^{2)}$	-	1,5 ⁴⁾										
Increasing factor for $N_{RK,p}$	$\psi_c^{5)}$	-	$\psi_c = \left(\frac{f_{ck,cube}}{25}\right)^{0,5}$										
Concrete cone failure and splitting failure⁶⁾													
Effective anchorage depth	h_{ef}	[mm]	30	40	40	50	50	65	65	80	75	100	
Slab thickness	h_{min}	[mm]	80	100	80	100	100	100	130	130	160	150	200
Factor for non-cracked concrete	k_{ucr}	-	10,1										
Spacing	$s_{cr,N}$	[mm]	90	120	120	150	150	195	195	240	225	300	
	$s_{cr,sp}$	[mm]	250	170	300	230	210	250	200	340	320	330	370
Edge distance	$c_{cr,N}$	[mm]	45	60	60	75	75	97,5	97,5	120	112,5	150	
	$c_{cr,sp}$	[mm]	125	85	150	115	105	125	100	170	160	165	185
Partial safety factor	$\gamma_{Mc}^{2)}$ $\gamma_{Msp}^{2)}$	-	1,5 ⁴⁾										

- 1) Use restricted to anchoring of structural components statically indetermined.
- 2) In absence of other national regulation.
- 3) The pull-out failure mode is not decisive for design.
- 4) The installation safety factor $\gamma_2=1.0$ is included.
- 5) Use concrete strength class according to EN 206-1, the maximum concrete strength is limited to $f_{ck,cube}=60N/mm^2$.

SPIT FIX3 torque-controlled expansion anchor

Design method A according to **CEN/TS 1992-4**
Characteristic resistances under tension loads

Annex C3

Table 8: Characteristic resistances in shear loads
 Design method A acc. **CEN/TS 1992-4**

Anchor size			M8 ¹⁾		M10		M12		M16		M20	
Effective anchorage depth	h_{ef}	[mm]	30	40	40	50	50	65	65	80	75	100
Steel failure without lever arm												
Characteristic resistance	$V_{Rk,s}$	[kN]	10,0		13,7		27,4		36,5		71,1	
Partial safety factor	γ_{Ms} ²⁾	-	1,25									1,50
Factor considering ductility	k_2	-	1,0									
Steel failure with lever arm												
Characteristic resistance	$M^0_{Rk,s}$	[N.m]	24,0		49,0		85,0		200,0		376,0	
Partial safety factor	γ_{Ms} ²⁾	-	1,25									1,50

Concrete pry-out failure												
k_3 factor	k_3	-	1,0	1,0	1,0	2,0	2,0	2,0	2,0	2,0	2,0	2,0
Partial safety factor	γ_{Mc} ²⁾	-	1,50 ³⁾									

Concrete edge failure												
Effective length of anchor under shear loading	l_f	[mm]	30	40	40	50	50	65	65	80	75	100
Outside diameter of anchor	d_{nom}	[mm]	8		10		12		16		20	
Partial safety factor	γ_{Mc} ²⁾	-	1,50 ³⁾									

- 1) Use restricted to anchoring of structural components statically indetermined.
- 2) In absence of other national regulation.
- 3) The installation safety factor $\gamma_2=1.0$ is included.

SPIT FIX3 torque-controlled expansion anchor

Design method A according to **CEN/TS 1992-4**
 Characteristic resistances under shear loads

Annex C4

Table 9: Displacement under tension loads

Anchor size			M8 ¹⁾		M10		M12		M16		M20	
Effective anchorage depth	h_{ef}	[mm]	30	40	40	50	50	65	65	80	75	100
Tension load for C20/25	N	[kN]	3,6	6,1	6,1	8,5	8,5	12,6	12,6	17,2	15,6	24,1
Displacements	δ_{N0}	[mm]	0,1	0,1	0,1	0,2	0,3	0,9	0,1	0,2	0,1	0,2
	$\delta_{N\infty}$	[mm]	1,1									
Tension load for C50/60	N	[kN]	5,5	9,4	9,4	13,2	13,2	19,5	19,5	26,7	24,2	37,3
Displacements	δ_{N0}	[mm]	0,1	0,3	0,2	0,4	0,8	2,4	0,2	0,8	0,2	1,1
	$\delta_{N\infty}$	[mm]	1,9				2,4		1,9			

1) Use restricted to anchoring of structural components statically indetermined.

Table 10: Displacement under shear loads

Anchor size			M8 ¹⁾		M10		M12		M16		M20	
Effective anchorage depth	h_{ef}	[mm]	30	40	40	50	50	65	65	80	75	100
Shear load for C20/25 to C50/60	V	[kN]	5,0		8,2		12,1		21,7		28,2	
Displacements	δ_{V0}	[mm]	2,1		1,2		1,6		1,7		3,8	
	$\delta_{V\infty}$	[mm]	3,2		1,8		2,4		2,5		5,7	

1) Use restricted to anchoring of structural components statically indetermined.

SPIT FIX3 torque-controlled expansion anchor

Design
 Displacements

Annex C5